

NORWOOD

NEVER ORDINARY

Product Information Guide **Doors**



Table of Contents

Table of Contents	1
Introduction	2
Maintenance and Care	3
Condensation	6
<i>Oxidation (weathering)of lead</i>	7
Finishing Wood Windows and Doors	8
Door Installation	10
Wood Warranty	16
Service Procedure	20
Warranty Card.....	21



Introduction

Thank you for choosing Norwood as your Door supplier. Our commitment to both quality and service has made us one of the industry leaders in the production of wood windows and doors.

For generations the skilled craftsmen at Norwood have been building high quality wood windows and doors to withstand the harsh realities of rugged North American winters. Today, the tradition continues with the complete line of low-maintenance and high-performance products from Norwood.

This manual will help you Install, Maintain and Care for your new Norwood Windows and Doors for many years of operation and beauty.



Maintenance and Care

This section of the manual will help you care for and maintain your Norwood Windows for many trouble free years.

Before Installation:

- Store Doors on a level surface in a dry, well-ventilated area.
- Keep the doors of the floor about 4 inches and cover them on the top and bottom. This will protect them from water, dirt and abuse it will also allow air circulation around the windows and doors.
- Do not store doors in direct sunlight. Windows and doors made from woods such as Cherry and Mahogany will discolor if exposed to direct sunlight in an unfinished state.
- Store doors in a temperature controlled building where temperature and humidity can be controlled. Recommended humidity levels should be between 35 to 55% and 10 to 25 Deg Celsius.
- Doors, should always be handled with clean hands or while wearing gloves.
- **DO NOT** drag doors they should always be lifted and carried when being moved.

After Installation:

Glass:

The glass surfaces can be cleaned using a mild soap or vinegar based solution. The exterior of the glass should be cleaned at least twice a year (more in some cases depending on the environmental conditions) and the interior cleaned as often as needed.

Caution: Avoid getting the cleaning solution on wood parts or the hardware as this may cause staining on the wood and remove the grease from the operating parts of the hardware.

Hardware:

Because of the wide range of environments that our products are installed, some cleaning and lubrication is required. The hardware and tracks of your windows should be checked at least once a year for a build-up of dirt and grime.



Cleaning:

Wipe the tracks and hardware using a mild soap solution.

Caution: Avoid using Vinegar, Citrus, Industrial and Abrasive cleaners on the hardware because they can remove the corrosion resistant coatings from the hardware.

Lubrication:

After the hardware has been cleaned and dried, it must be lubricated. It is recommended that lithium grease be used because of its waterproofness. Apply a light coating of grease to the track, pivot points, and gears on the hardware.

Note: Avoid using petroleum based lubricants such as oil or petroleum jelly as it will stay wet and attract more dirt.

Warning: Avoid getting any grease on the wood parts because it may cause staining and damage to the surface.



Norcoat Flexacron Paint and Stain Finish

The Norcoat Flexacron coating is a premium quality, high performance finish and requires minimal maintenance.

Light accumulation of dirt can be removed using a garden hose equipped with a soft bristle brush. Heavier accumulations can be removed using a mild soap solution. For wet paint, tar and caulking use kerosene or mineral spirits. **DO NOT** use stronger solvents or abrasive type cleaners because they will damage the paint surface.

Mildew thrives on warmth and moisture that is most common near water such as the Great Lakes, the coast and other large bodies of water. If you live in an area of high humidity you should inspect your windows regularly for the presence of mildew and clean as needed, however, because mildew is so adaptable it can flourish in almost any climate.

Cracks resulting from joint movement should be caulked with high quality caulking materials such as Dow-734 silicone.

Minor nicks and scratches may be touched up with a matching Pittsburgh Paint 78-Line Sun-Proof semi-gloss acrylic latex paint.

Condensation

What is condensation?

Condensation happens when there is too much moisture in the air at a certain temperature. When the warmer moist air comes in contact with a cooler surface it reaches its dew point causing “sweat” or condensation on the cooler surface.

There are several interior surfaces where condensation can appear in your home; cold water pipes, toilet tanks, door hinges, and windows. These surfaces usually have a cooler surface temperature than the air around them and therefore when the warmer moist air comes in contact with them condensation (sweating) occurs.

A good example of condensation is the sweat on the bathroom mirror after a shower. Because the mirror has a cooler surface temperature than other surfaces in the bathroom the moisture in the air from the shower collects and forms condensation on the surface of the mirror. If the exhaust fan is running during the shower the amount of condensation on the mirror is significantly reduced.

The table below shows recommended relative humidities for different outside temperatures. The table shows that as the outside temperature drops so should the relative humidity within the home to minimize condensation.

Outside air temperature in degrees C	Relative Humidity with inside air temperature of 20 degrees C
-30 or below	not over 15%
-30 to -24	not over 20%
-18 to -12	not over 25%
-12 to -6	not over 30%
-6 to 0	not over 40%

Sources of humidity in the home:

Humidity is released in the home through normal daily activities such as:

- Cooking
- Washing machines, dryers and dishwashers
- Showering
- Watering house plants etc.

Ways to help control humidity:

- Run exhaust fans while cooking, bathing or cleaning.
- Have all fans vented to the outside.
- Vent attic and crawl spaces.
- Open a door or window for a short time to allow moisture to escape.
- Open blinds and drapes during the day and during the night raise the blinds at least 5” to allow for air flow against the glass

Oxidation (weathering) of lead

We advise that your sales personnel are briefed, and that they inform potential customers of the natural oxidation of lead.

All newly installed lead products, when exposed to the atmosphere are subject to an oxidation process and will form a naturally protective grey patina. During the initial stages of this process lead can display various colours including blue, bronze and even green. When lead comes into contact with moisture i.e. rain, water, condensation etc., at an early stage, discoloration, spotting and white powdery deposits (usually basic carbonate) can form and may “run-off”. The degree to which these effects occur is governed by the environmental conditions but with longer term weathering the lead will take on its familiar grey appearance. Should these deposits become unsightly they can be removed by a very gentle rubbing with wire wool; extreme care should be taken not to disturb the underlying film (patina).

This Process can be controlled by the application of **Decra Led Patination Oil** (apply to bright lead). This dries to a dull, matt finish and provides a “screen” to the environment. (As Patination Oil had to be applied extremely carefully, to avoid leaving any residue on the glass)

STORAGE

The storage life of **Decra Led** in a temperate climate is 2 years, providing it is stored in original sealed carton. **Decra Led** should not be stored in areas that may be subject to excessive heat, moisture, corrosive, or solvent fumes. Minor surface defects and slight oxidation may occur during transit or storage; these will not affect the service life or the product and are often removed during cleaning.

HEALTH AND SAFETY

Decra Led is a clean bright metallic lead therefore no health hazard is likely to occur. However certain basic handling precautions should be observed: eating, drinking and smoking should be prohibited in areas where lead is used. Personal hygiene and good housekeeping is important wash hands and face thoroughly after use and especially before eating, drinking or smoking. Area where lead is used should be cleaned daily, preferably vacuumed.

FIRST AID CUTS & ABRASIONS

Clean and apply sterile dressing- medical aid should be obtained if necessary.



Finishing Wood Windows and Doors

Finishing Windows

All natural unfinished products must be finished immediately to prevent damage to the wood, even if the wood is primed. The function of the primer is to maximize adhesion between the wood and paint, not protection against the elements.

- Do not apply stain or paint to weather stripping, hardware, plastics or vinyl or any other non-wood parts.
- Clean and dry any wood surfaces before finishing. Remove any handling marks or blemishes using 220 grit sandpaper. Sand in the direction of the grain and remove dust using a tack cloth.
- Choose a high quality stain or paint and apply according to manufacturer's instructions.

Note: When using an unfamiliar stain it is always a good idea to experiment on scrap wood or a concealed location before completing the whole project.

Norwood does not warrant the appearance or applications of any field applied stains or paints.

- Paint or stain windows with sash opened or removed and do not close or reinstall until thoroughly dry.

Finishing Doors:

- Lay door flat in a clean dry area.
- Remove all hardware (hinges, locksets, kick plates, etc...).
- Cover all glass or other permanent non-wood parts.
- Sand wood in the direction of the wood grain using 220 grit sandpaper. This is done to remove any scuffs, raised grain, handling marks and any other unwanted blemishes that the door may have. Sanding also opens the wood grain which allows it to receive a more even finish especially in solid core doors.
- Remove dust using a slightly moist sponge or tack cloth and allow to dry completely.

Note: Dark colored finished may cause warping and veneer checking if exposed directly in sunlight and therefore should be avoided.

- The finish used must have the following:
 - A). Contain ultra-violet Protection.
 - B). Applied to give at least a three coat application.
 - C). Applied as per stain manufacturer's instructions.

NORWOOD

NEVER ORDINARY

Note: Some water based coatings on unfinished woods may cause veneer splits, highlight joints and raise wood grain. Doors must be properly sealed and adequately protected from the elements. Norwood is not responsible for the final appearance of a field finished door.

- All six (6) surfaces should be finished. (TOP, BOTTOM, BOTH EDGES and FRONT and BACK).
- Apply several extra coats of finish on the top and bottom of the door to prevent moisture from entering the open end grain.
- All cutouts for hardware should also be finished and sealed prior to installation.
- Allow adequate drying time between coats of finish as per manufacturer's recommendations.
- After the finish has dried apply a fine bead of sealant along the top, bottom and face of all grooves on the exterior.
- Reinstall all hardware once door is completely dry.

Window and door exterior finishes should be inspected periodically for blisters, cracking or peeling and repaired immediately to protect the wood underneath.





Door Installation

Step 1:

Unpack the Door:

- Remove all cardboard wrapping and shipping blocks.
- Remove all strapping.
- Remove any dirt and dust from all trims with a clean cloth; this is to ensure that the silicone and flashing will stick.

Step 2:

- Check the rough opening (RO):
- Make sure that the opening is level, square and plumb.
- Measure the opening, the opening should be ½” larger than the door in width and ½” height. Measures should be taken in several locations in the height (bottom, center and top) and for wider doors in width (left, center and right) to ensure that the studs or header is not bowed.

Note: If a pre-manufactured sill pan is being used, the height of the sill pan must be added to the height of the R.O. Any problems found with the opening should be corrected before you continue.

Step 3:

Cutting the weather resistant barrier:

- Cut the weather resistant barrier in the same manner as described in Step 3 of the window installation section.

Step 4:

Installing the sill pan:

- Prepare the corrosion resistant sill pan as described in Step 4 of the window installation.

If a Pre-manufactured sill pan is being used, install it in accordance to manufacturer’s instructions.

- Place sill pan in the opening for a “dry fit”.
- Remove the sill pan and put three 3/8” beads of silicone on the sill.
- Put 3/8” bead of silicone on the inside of the downward lip of the sill pan.
- Place sill pan back into opening and press into silicone to ensure a good fit.
- Fasten sill pan to framing using corrosion resistant screws 16” on center.
- Cover the heads of the screws with silicone.

NORWOOD

NEVER ORDINARY

Step 5:

Installing the Door:

Note: All Norwood Doors are installed using installation straps screwed to the side of the door (at the factory) and fastened to the framing from the inside.

- **This is at least a two person step, one person outside holding the door and one person inside to fasten the door to the framing.**
- Put a continuous 3/8" bead of silicone around the sides and top of the door behind the exterior casing.
- Put a 3/8" bead of silicone on the back wall of the sill pan toward the door sill.
- Place the door in the opening and center it.
- Plumb and square the door using shims.
- Shims **MUST** be placed at each hinge location and at the lock strike location.
- Check the door to ensure that the clearance between the panel and the frame is consistent. The clearance should be 1/8".
- Bend the installation straps over the interior framing and secure with screws.
- Open the door and install the #10 2 1/2" wood screw supplied in the predrilled holes in the hinges of the door jamb. The screws **MUST** be driven through the jamb and into the stud in order to support the weight of the door.
- With the #10 2 1/2" screws provided, screw the sill to the floor through the predrilled holes in the crown.

Note: The sill **MUST be secured to the floor before the silicone cures. If the sill does not set straight on the floor this will cause a bow in the center, causing the door not to operate correctly, this will void the warranty.**

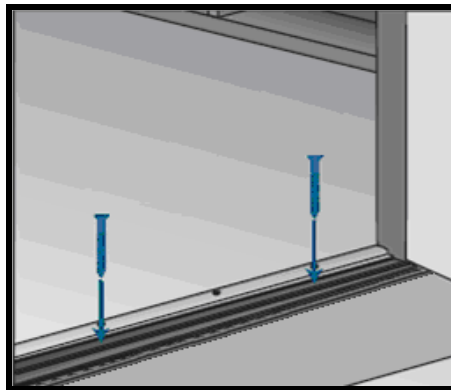

NORWOOD

NEVER ORDINARY

For Double doors the head jamb should be fastened to the header in the center of the jamb through the head strike plate using the #10 2 ½" screw provided.

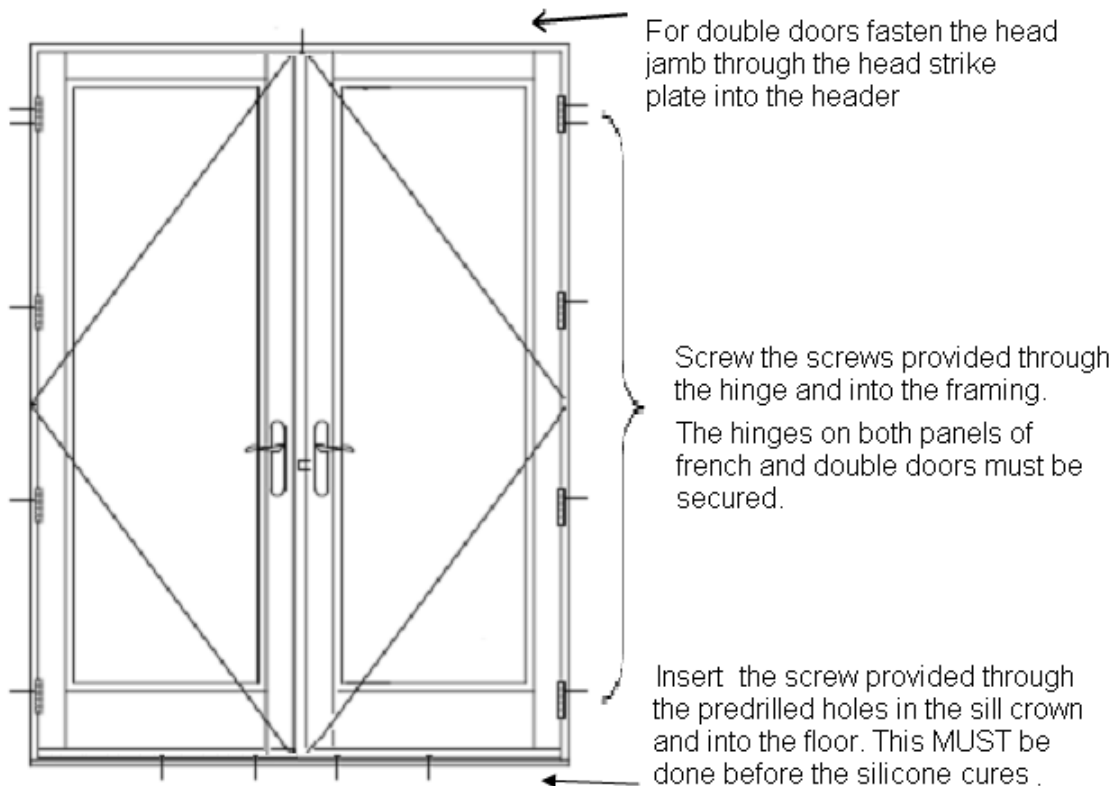

Step 6:

Installing Drip cap:

- Cut galvanized drip cap ¼" longer than width of door.
- Apply ¼" bead of silicone to top of the exterior trim of the window and the wall.
- Center drip cap over door on top of exterior trim and nail in place. Place nails in the exterior wall sheathing not through the top of exterior trim. Put silicone on the heads of the nails.

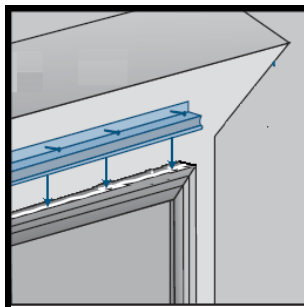

Step 7:

Applying self adhesive flashing:

- Cut 2 pieces of self-adhesive flashing 12" longer than the height of the Door and 1 piece 14" longer than the width of the door.
- Apply the two longer pieces of flashing tight to the exterior trim (1 piece on each side). Allow the flashing to go above the door 5" on each side.
- Apply the third piece of flashing at the top of the door tight to the exterior trim.
- Fold the weather barrier (temporarily stapled up above Door) down over the flashing at the top of the Door. Secure in placing using building tape or silicone.
- Place tape over the diagonal cuts in the weather barrier at the top of the Door.

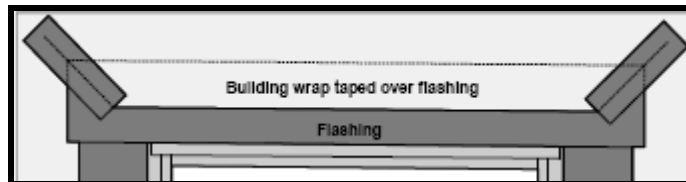

Step 8:

Finishing the installation:

- You could use either fiberglass insulation or low/minimal expansion foam to insulate the door.

Note: DO NOT pack fiberglass insulation too tight. FOLLOW ALL manufacturer's installation instruction on any expanding foam used.

- After the exterior finish is complete silicone the sides and top of the door.

NORWOOD

NEVER ORDINARY

Patio door adjustments

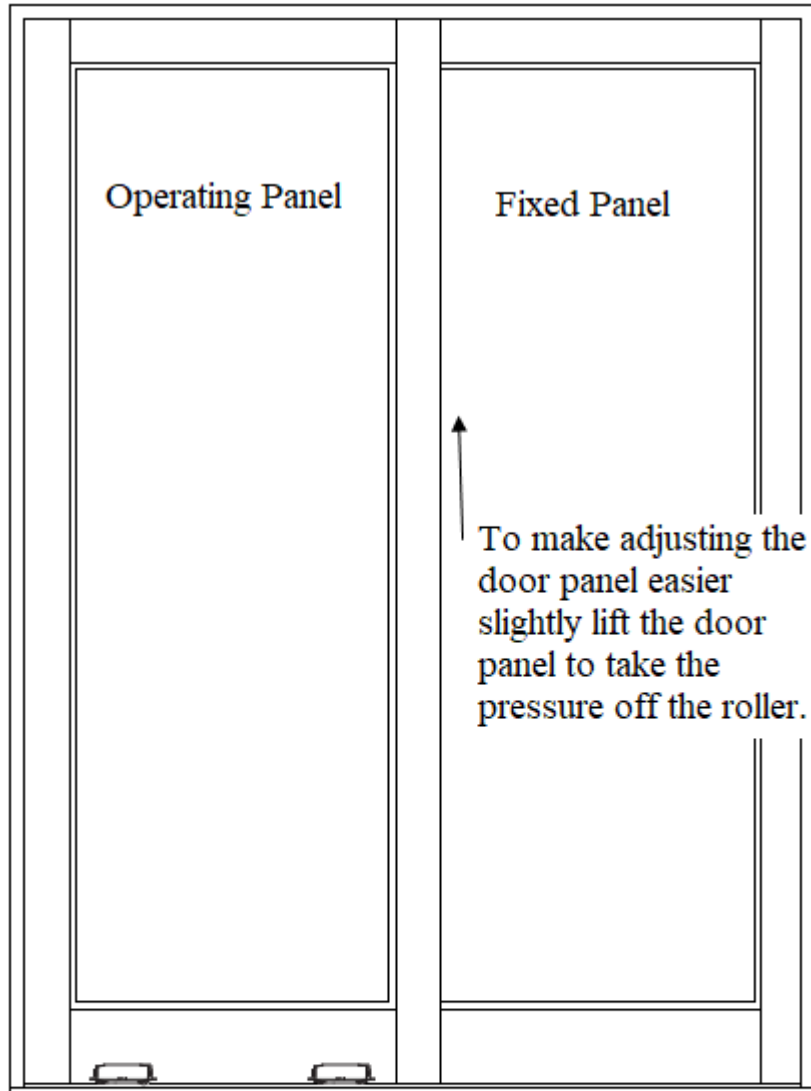

Rollers adjustment screws
are located 6 to 8 inches
from edge of door

Inside View

Measure here

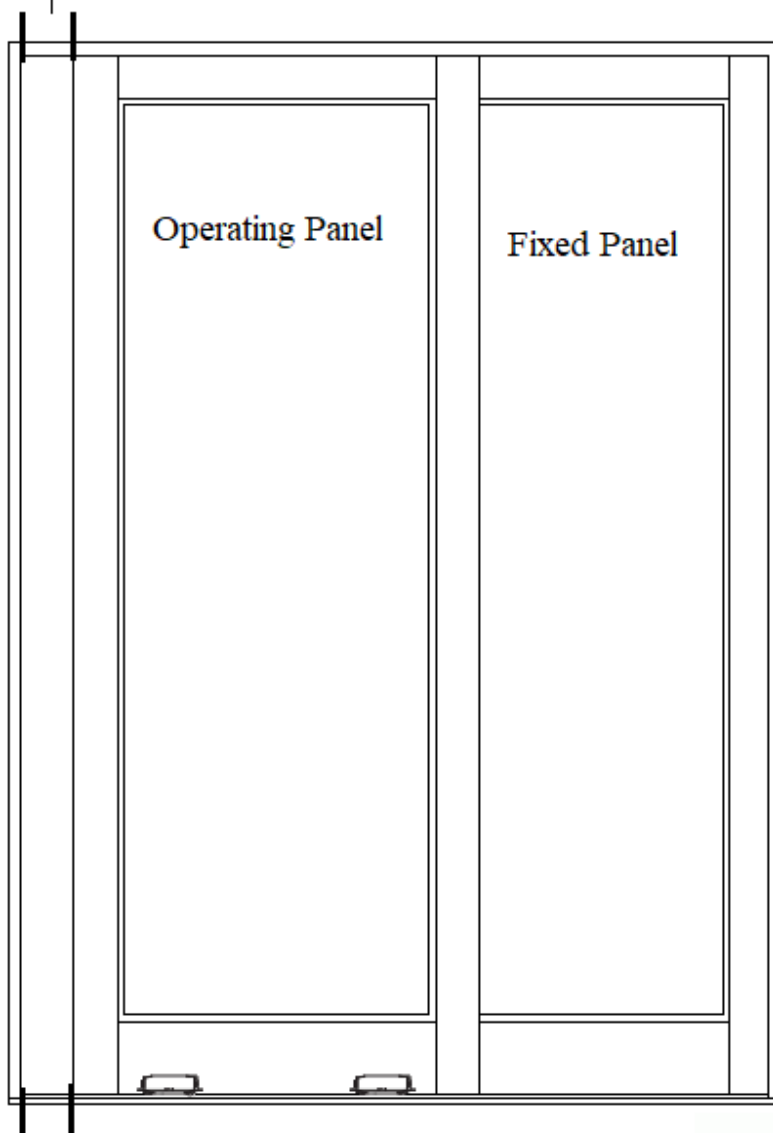

Measure here

Open door panel 1 to 2 inches Measure the distance from the Jamb to the panel on both top and bottom.

If the two measurements are the same no justments may not be necessary.

If the measurements are different adjust the rollers as required, using the screwdriver provided, so the measurements are the same at the top and bottom of the opening.

If the door is still hard to operate once the distance is the same adjust both rollers 1/4 turn or until the panel rolles freely.

Wood Warranty

This document sets out the various warranties which Norwood gives to the original purchaser of products manufactured by Norwood. This warranty is nontransferable and is valid to the original owner of the building where the product is installed.

Natural Wood/Norcoat Flexacron

A. Insulated Glass

- **Norwood**, as manufacturer, warrants all insulated glass, except when installed as TDL (True Divided Lights), from seal failure for a twenty (20) year period from the date of manufacture.
- TDL (True Divided Light) sealed units are warranted for one (1) year from the date of manufacture.

Norwood warrants that all glass units be free from stress cracks for a period of two (2) years from the date of manufacture.

Should there be a failure of the air seal within the limited warranty period, **Norwood** shall, at their discretion:

- Either replace the defective insulated glass, or a sash glazed with insulated glass, at no charge within a period of two (2) years from date of purchase.
- Years three (3) to Twenty (20) from date of purchase, **Norwood** shall, at its own discretion, provide a replacement piece of insulated glass, or a sash glazed with insulated glass, delivered to the original point of purchase. The customer will be responsible for installation and replacement of the glass.

Norwood will not be responsible for repainting, refinishing, or similar activities involved in the installation and replacement of glass at any time.

This warranty does not cover:

- Cracked or broken glass or damage to product resulting from accident, abusive handling or misuse, shattering due to heat build-up or any cause beyond the control of **Norwood** such as fire, flood and any act of nature.
- Any units where there is film applied to the surface of the glass.
- Minor glass imperfections that do not affect normal vision or product performance. Normal manufacturing defects considered as acceptable by the Canadian industry standard are imperfections such as scratches that are invisible

to the naked eye more than one meter from the glass.

B. Wood Items

Norwood warrants the quality of workmanship and materials of wood items to be free from defects which might render the product unserviceable for two (2) years from the date of manufacture.

Norwood suggests inspection of all products upon arrival and before installation and finishing. To comply with this limited warranty, it is the consumer's responsibility to properly care for and protect all wood items against moisture, excessive dryness, etc. and see that all surfaces, interior and exterior, top and bottom of wood items, are thoroughly painted, varnished, or sealed by accepted field finishing standards.

Norwood will replace or repair any products which may be defective and will do so in the same state as originally supplied.

Norwood will not, however, be responsible for the installation or any refinishing work associated with replacement of these parts

This warranty does not cover:

- **Any natural unfinished or primed product after it leaves the factory.**
- Variations in color, grain, texture or normal wear of the wood does not constitute defects in wood items.

C. Hardware, Weatherstripping, Screens Etc.

Norwood provides a limited warranty against defects or error in workmanship for a five (5) year period from the date of manufacture.

These products are generally manufactured by others and provided to us as finished items to incorporate into our products. Within that time period **Norwood** will provide replacement materials at no charge. The customer will be responsible for installation of these materials.

Norwood will not, however, be responsible for the installation or any refinishing work associated with replacement of these parts.

This warranty does not cover:

- Any hardware or weatherstripping that has been painted or coated with any substance that could interfere with the operation of the part.
- Normal wear or tear and natural weathering on surfaces.
- Damage to surfaces caused by chemicals used for such activities as brick washing.
- Abuse by on site construction.

D. Norwood Flexcron Finishes

Norcoat coatings (2603), as supplied by **Norwood** are guaranteed not to crack, peel or blister for a period of fifteen (15) years from date of application when used under normal atmospheric conditions.

Norwood's liability under this warranty will be limited to all cost related to refinishing or replacing the defective part. **Norwood** will, in all instances, have the option of determining which of the above shall be utilized to fulfill this obligation as well as what materials will be used in the event of refinishing. Claims under this warranty must be made to **Norwood**, in writing, within thirty (30) days of discovering a defective unit.

This warranty is exclusive to Norcoat finish on **Norwood** products.

This warranty does not cover:

- Product which has been physically damaged during installation or delivery.
- Damage to the finish system induced by excessive movement of the substrate.
- Normal color changes (Fading) due to environmental exposure.
- Unacceptable color changes or staining due to migration of naturally occurring resins or pitch from the substrate through to the surface of the finish.
- Damaged areas that have been improperly touched-up or touched-up by materials that were not approved by **Norwood**.
- Product that has been exposed to chemicals or other corrosive substance or corrosive environments.

E. Norwood Stained and Clear Coat Finishes

Norcoat stained product, as supplied by **Norwood**, are guaranteed not to crack, peel or blister for a period of one (1) year from date of application when used under normal atmospheric conditions.

Norwood's liability under this warranty will be limited to all cost related to refinishing or replacing the defective part. **Norwood** will, in all instances, have the option of determining which of the above shall be utilized to fulfill this obligation as well as what materials will be used in the event of refinishing. Claims under this warranty must be made to **Norwood**, in writing, within thirty (30) days of discovering a defective unit.

This warranty does not cover:

- Windows and doors without the correct overhang as described on page four (4) of this warranty.
- Product which has been physically damaged during installation or delivery.
- Damage to the finish system induced by excessive movement of the substrate.
- Unacceptable color changes or staining due to migration of naturally occurring resins or pitch from the substrate through to the surface of the finish.
- Damaged areas that have been improperly touched-up or touched-up by materials that were not approved by **Norwood**.
- Product that has been exposed to chemicals or other corrosive substance or corrosive environments.

F. Steel Door

Norwood will provide, to the original owner, a limited warranty on steel door slabs against defects, warpage, or error in workmanship for five (5) years from date of purchase.

Within that time period, the manufacturer will replace defective material at no charge.

Norwood will not, however, be responsible for the installation or any refinishing work associated with replacement of these parts.

This warranty does not cover:

- Doors with cut-outs over 21" x 65" on the 32" and 34" doors and 24" x 65" on 36" doors.
- Door warpage is not covered by warranty when cut-outs are greater than the above.
- Door warpage is considered a defect when the deflection exceeds 5mm or 1/4", providing the door is manufactured with standard locks and hinge preparation.
- Dents, scratches or damage after the door has been delivered.

G. Wood Door

Norwood warrants the quality of workmanship and materials of wood items to be free from defects which might render the product unserviceable for two (2) years from the date of manufacture.

All aspects of our written warranty on wood, glass and hardware are applicable with this product; however, millwork items such as this must receive special care and treatment if they are not completely pre-finished at the factory.

Within the time period, **Norwood** will, at its option, either repair or replace without charge; the defective item in whatever stage of finish it was original supplied. Written notice of any claim under this warranty must be given to **Norwood** within ten (10) days if we have made an error or if millwork proves unsatisfactory.

This warranty does not cover:

- **Norwood will not warranty any natural unfinished or primed product after it leaves the factory.**
- Warping shall not be considered a defect unless it exceeds ¼" in the plane of the door itself and does

not refer to the relationship of the door to the frame or jamb in which it is hung.

- Warping of doors without a factory installed multipoint lock.
- Units which are improperly installed.
- Improper treatment or failure to follow finishing instructions.
- The appearance of the field finished door is not warranted under any circumstances.
- Air and water infiltration due to nature of product (french door only).
- Variations in color, grain, texture or normal wear of the wood does not constitute defects in wood items.
- Under these circumstances, it is the homeowner's responsibility to properly care for and protect new wood against moisture or excessive dryness and see that the top and bottom edges and all other surfaces of doors are thoroughly painted or varnished.

This warranty as outlined in paragraphs A, B, C, D, E, F & G is limited to defects in workmanship and materials and does not cover damage or defects caused by or arising from:

1. Damage occurring in transit (by a carrier other than Norwood) after the item leaves the **Norwood** plant, or on-site damage occurring during construction through vandalism, or from any other cause beyond **Norwood's** control.
2. Improper handling or installation by the builder or customer, or the failure of the builder or the customer to follow **Norwood's** instructions.
3. Installation of the window or door in its opening in a manner that is not exactly plumb, square and true and adequately shimmed as described in the installation instructions supplied with each product.
4. The unit is being subjected to stresses resulting from localized application of heat which causes excessive temperature differential over the glass surface or edges, or if strain is applied to the unit by movement of the building, or if provisions have not been made in accordance with sound practice for adequate expansion or contraction of framing members.
5. Claims involving the improper installation and/or finishing where such work was not originally performed by **Norwood**.
6. Exposure to weather in unfinished state.
7. French inswing casements installed in high exposed areas are not warranted against water or wind infiltration.
8. Labor to install any replacement warranted parts is covered for 2 years at Norwood's discretion.
9. Splits, dents, scratches and finish deterioration on wood and aluminum door sills and crown after the door is installed.
10. Any sized units having dimensions greater than those listed in Norwood's catalog.
11. Discoloration or weathering of hardware finishes.
12. Air or water infiltration or damage on site mullied product.
13. Norwood recommends that inspections be carried out yearly on factory applied finishes and any mildew cleaned, breaches in the finish and lifting of stain top coat be repaired. In high exposed areas stained product may have to be refinished annually.

Dealers should note that the Norwood will invoice replacement parts at regular price, and in turn issue full credit when defective parts has been returned for inspection for warranty approval.

In consideration of the above express warranties extended by Norwood, all other warranties or conditions, either expressed or implied whether arising by statute or otherwise, including warranties of merchantability and fitness for a particular purpose are excluded.

In no event shall Norwood be liable for indirect or consequential damages such as the cost of repairing or replacing property damage as a result of product failure.

Norwood stained Product warranty Limitations

Norwood's one year warranty on its stained product is subjected to the following condition.

Placement and overhangs:

Placements of stain product in a home will determine its maintenance and longevity. To protect and extend the life of the stained product you need to consider the direction the product will be facing which will determine the amount of overhang that is required. Also there are some situations where the exposure can be too extreme for a wood door.

Below is a formula to help determine the correct overhang for Norwood's stained product.

Y = distance from bottom of window or door to base of overhang

X = overhang distance required

Direction

South X = Y

North X = 1/2Y

East X = 1/2Y

West X = Y

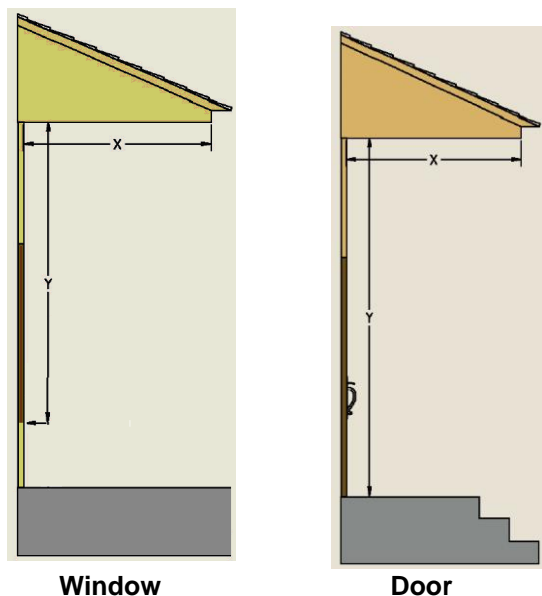

Stained product without adequate overhangs may experience problems such as rapid finish deterioration, color fading, wood splitting, molding shrinkage, wood joint separation and penetration between molding, panels and glass.

Without the minimum overhang over the stained products Norwood's warranty will be void.



Service Procedure

Norwood Windows is committed to its product long after it leaves the factory. If you require service on your product please follow the procedure listed below.

1. **Read your warranty before you make a warranty claim.**
2. **Contact the dealer where you purchased your product.**

Your dealer is the best source for your service assistance. They have the experience and ability to solve many of your service issues.

In the event that the dealer is unable to solve the problem:

3. An **After Sales Service Report should be filled out** by the dealer, and sent to Norwood Windows. This report should include the dealers name and address, the Customers name and address, date purchased, original order and line numbers, the nature of the complaint and digital photos (where possible).

After all the relevant information is received, Norwood's service coordinator will evaluate the claim and inform the dealer of any corrective action that will be taken.

Note: Prior written approval will be required before service work is performed by outside contractors or dealers and inside technicians with transferable cost to Norwood. Norwood reserves the right to charge a fee for on-site inspections if required.

NORWOOD

NEVER ORDINARY

Warranty Card

Please complete and mail this Warranty Card within 90 days after receiving your windows and doors to register your Norwood Warranty.

Owners Name: _____

Owners Address: _____

City: _____ *State:* _____ *Zip:* _____

Purchase Date: _____ *Dealer:* _____

Warranty Department
Norwood Windows
249 Parker Rd.
Scoudouc, NB
E4P 3P8